

**Serie | 8, 177.8 x 91.2 cm, Black  
KAD92HBFP**



**Side-by-Side fridge freezer with innovative noFrost technology and cameras: the cameras in the fridge let you check the content of your fridge from wherever you are, whenever you want.**

- Smart Food Management, thanks to intelligent cameras in the fridge
- **Home Connect:** home appliances with smart connectivity for an easier everyday life.
- **Extra Large size:** provides much more space for your food.
- LED lights bring a completely new lighting concept to fridges
- **BigBox frozen food drawer:** for stacking storage containers or for large frozen food items.

**Technical Data**

Energy Efficiency Class (Regulation (EU) 2017/1369):	F
Average annual energy consumption in kilowatt hour per year (kWh/a) (EU) 2017/1369:	419
Sum of volume of frozen compartments (EU 2017/1369):	209
Sum of volume of chill compartments (EU 2017/1369):	376
Airborne acoustical noise emissions (EU 2017/1369):	42
Airborne acoustical noise emission class (EU 2017/1369):	D
Construction type:	Free-standing
Door panel options:	Not possible
Height (mm):	1778
Width of the product (mm):	912
Depth of the product:	732
Net weight (kg):	159.442
Connection rating (W):	190
Fuse protection (A):	10
Door hinge:	Left & Right
Voltage (V):	220-240
Frequency (Hz):	50-60
Approval certificates:	CE, VDE
Length of electrical supply cord (cm):	240
Storage Period in Event of Power Failure (h):	8
Number of compressors:	1
Number of independent cooling systems:	2
Interior ventilator:	No
Reversible Door Hinge:	No
Number of Adjustable Shelves in fridge compartment (Stck):	3
Shelves for Bottles:	Yes
Capacity of Water Tank [l]:	1.0
EAN code:	4242005150205
Brand:	Bosch
Product name / Commercial code:	KAD92HBFP
Frost free system:	Fridge and freezer
Installation type:	N/A

**Included accessories**

- 2 x cold accumulator
- 1 x connection hose
- 1 x egg tray

**Optional accessories**

- FIZ50000 : Water filter
- KSZ63000 : water hose extension



## Serie | 8, 177.8 x 91.2 cm, Black KAD92HBFP

**Side-by-Side fridge freezer with innovative noFrost technology and cameras: the cameras in the fridge let you check the content of your fridge from wherever you are, whenever you want.**

### Design features

- Aluminium Vertical door handle
- Electronic control (external in-door LCD display)

### Functions

- No Frost, never have to defrost ever again
- Separate temperature control for cooling and freezing section
- Super Cooling: automatic deactivation
- SuperFreezing function with automatic deactivation
- Optical and acoustical door open warning
- optical and acoustical warning system with failure memory function, optical and accoustical

### Ice and Water

- Illuminated water and ice dispenser
- Automatic ice cube maker
- Internal water filter

### Food freshness system

- MultiAirflow system - improves circulation of air around the fridge
- 1 VitaFresh drawer - Fish and meat stay fresh for longer
- 1 MultiBox drawer on telescopic rails - Transparent drawer with a corrugated bottom, ideal for storing fruits and vegetables.
- VitaFresh Plus container on telescopic rails with humidity control for prolonged food storage,

### Key features - Fridge section

- 2 removable door storage compartments.
- 4 safety glass shelves of which 3 are height adjustable
- 4 height adjustable feet

### Key features - Freezer section

- 4 door trays in the freezing compartment
- 2 freezer drawers

### Included accessories

- 2 x cold accumulator, 1 x connection hose, 3 x egg tray

### Dimension and installation

- Dimensions: 177.8 cm H x 91.2 cm W x 73.2 cm D
- Connection value 190 W
- 220 - 240 V
- Based on the results of the standard 24-hour test. Actual consumption depends on usage/position of the appliance.
- To achieve the declared energy consumption, the distanceholders have to be used. As a result, the appliance depth increases by about 3.5 cm. The appliance used without the distance holder is fully functional, but has a slightly higher energy consumption.

### Performance and Consumption

- EU19\_EEK\_D: F
- Total Volume : 585 l
- Net Fridge Volume : 376 l
- Net Freezer Volume : 209 l
- Freezing capacity 24h : 15 kg
- Annual Energy Consumption: 419 kWh/a
- Climate Class: SN-T
- EU19\_Fast freezer facility\_D
- Noise Level : 42 dB
- Temperature rise time : EU19\_Temperature rise time\_D: 8.5 H

**Serie | 8, 177.8 x 91.2 cm, Black  
KAD92HBFP**

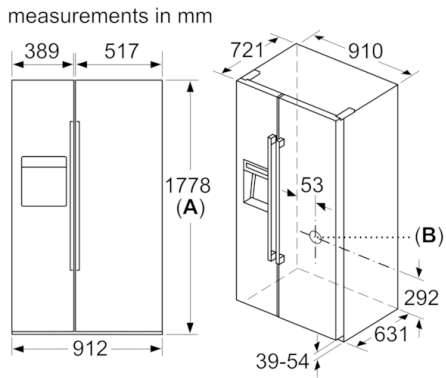
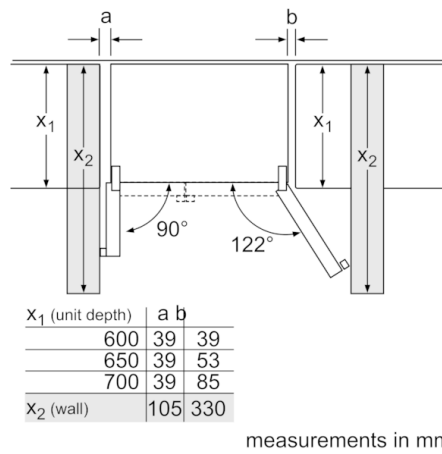
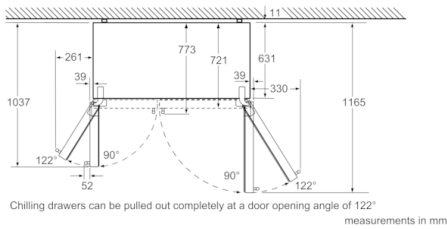

**A:** Front is adjustable from 1769 to 1784  
**B:** Water connection to the appliance